

**1997-98 Ford F-Series Pickup**  
**1998 Ford Expedition**

**RADIO REMOVAL:**

- Carefully pry out on radio/dash bezel and unsnap to remove.  
**CAUTION: PASSENGER AIRBAG SWITCH DOES NOT UNPLUG ON PICKUP.**
- Insert DIN Removal Tools, spread the tools apart to release factory stereo, slip it out of the dash and remove radio.

**FD1327 KIT PREPARATION**

- Snap the short pocket to kit panel instead of the full CD pocket.
- When installing kit into dash, the pocket should be on top.

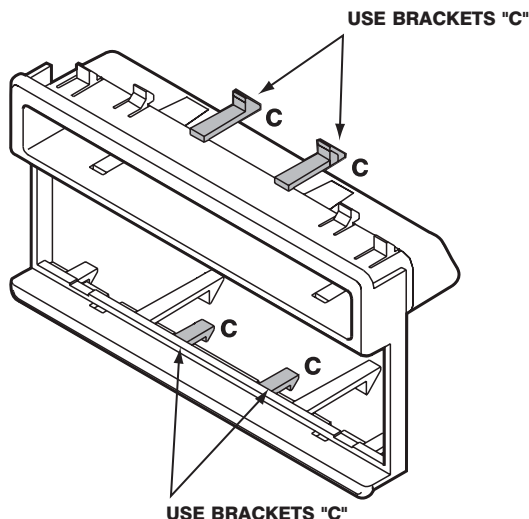

**USE THE SHADED BRACKETS. CUT OFF THE REMAINING BRACKETS AND DISCARD.**

**IN-DASH INSTALLATION KIT FOR  
 SELECT 1995-UP FORD VEHICLES**

**FORD**

1997-04	CLUB WAGON
1995-04	CROWN VICTORIA
1997-04	ECONOLINE
2001-05	ESCAPE
2000-04	EXCURSION
1998-02	EXPEDITION
1995-01	EXPLORER
2001-03	EXPLORER 2-DR SPORT
2001-03	EXPLORER SPORT TRAC
1997-03	F-SERIES PICKUP
2004	F-SERIES PICKUP HERITAGE
1999-04	F-SERIES SUPER DUTY PICKUP
1995-03	RANGER
1999-03	WINDSTAR

**LINCOLN**

2002-03	BLACKWOOD
1995-97	CONTINENTAL
1995-98	MARK VIII
1998-04	NAVIGATOR
1995-04	TOWN CAR

**MAZDA**

1995-03	B SERIES PICKUP
---------	-----------------

**MERCURY**

2001-03	COUGAR
1995-03	GRAND MARQUIS
1996-01	MOUNTAINEER

**CAUTION:**  
 REAR SUPPORT  
 AVAILABLE  
 SEPARATELY. REAR  
 SUPPORTING THE  
 RADIO ADDS TO  
 THE INSTALLA-  
 TIONS STRUCTURAL  
 INTEGRITY.

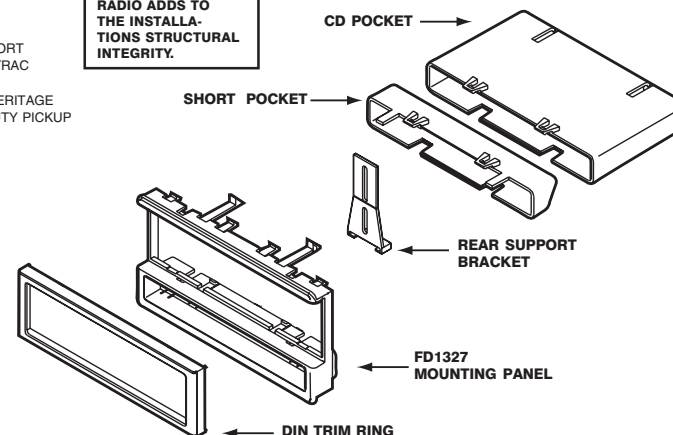

**WIRE CODES**

**NOTE:** For Factory Wiring Codes go to: [www.scosche-cars.com](http://www.scosche-cars.com)

**INTRODUCTION**

This premium installation kit is for 1995-UP select Ford vehicles. Included are all the parts you need to mount your car stereo/cassette or CD player into your vehicle's dash. Refer to the individual instruction in this manual to remove your vehicle's factory radio and assemble the kit.

**CAUTION:**  
**DISCONNECT YOUR VEHICLE'S NEGATIVE BATTERY TERMINAL BEFORE THE INSTALLATION TO HELP PREVENT ELECTRICAL DAMAGE. WE RECOMMEND THE USE OF A VOLT/OHM METER OVER A TEST LIGHT TO CHECK WIRING. A TEST LIGHT OR GROUNDED WIRE PROBE CAN CAUSE DAMAGE TO THE VEHICLE'S COMPUTER AND/OR DIAGNOSTIC SYSTEMS. AVOID ALL FACTORY AIR BAG WIRING - AIR BAGS CAN ACCIDENTALLY DEPLOY CAUSING SERIOUS INJURY OR DEATH.**

- NOTES:**
- See your vehicle's instructions for any special tools your installation might require.
  - Read all instructions accompanying your car stereo/cassette player for proper wiring and mounting instructions.

**LIABILITY DISCLAIMER**  
 This instruction booklet is based on carefully documented data and research of automobile dash disassembly, wire harness/codes and information pertaining to installation of this kit (FD1327) in Select 1995-UP Ford Vehicles. Scosche Industries, Inc. can not be held responsible for discrepancies/ inconsistencies that may occur due to the automobile manufacturing changes or options, or damage that may occur in the automobile during the installation of components while using this booklet.

If you have any further questions, call:  
 ©2005 SCOSCHE INDUSTRIES, INC.

**TECH HELP 1-800-621-3695 x3**

SI 02/05 - FD1327B (3000372)

## POCKET INSTALLATION

### POCKET INSTALLATION

1. Locate and align bottom guides and top snaps of the pocket to kit panel.
2. Slide pocket on bottom guides while the top snaps are aligned.
3. When aligned properly the top pocket snaps will lock to kit panel.

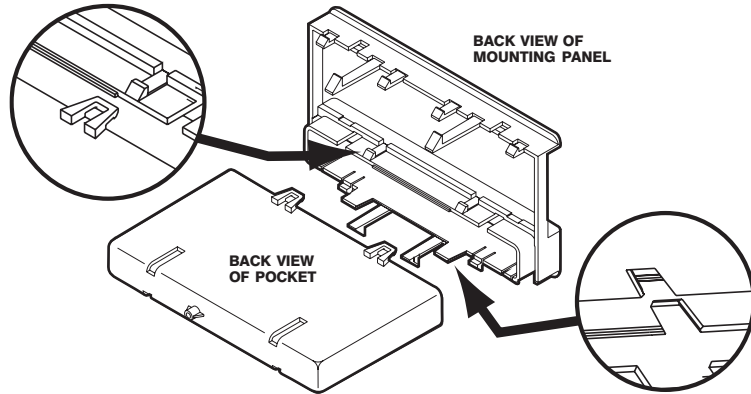

## KIT INSTALLATION

### STEREO INSTALLATION

1. See Illustration "A" for kit assembly with DIN or Illustration "C" for Shaft stereos.
2. Be sure to attach rear support bracket provided in the installation kit to the back as shown in Illustrations "A" and "C".
3. Connection the stereo to the factory wiring as directed in the stereo's owners manual. Scosche recommends the use of an FD02/FD16 connector set when connection to the factory wiring. The FD02/FD16 connector will plug into the wiring in the vehicle and eliminate the need to cut and splice into the factory wiring.

### ILLUSTRATION "A"

#### DIN RADIOS:

The kit comes DIN ready. Following the instructions supplied with the radio, secure the radio to the mounting kit.

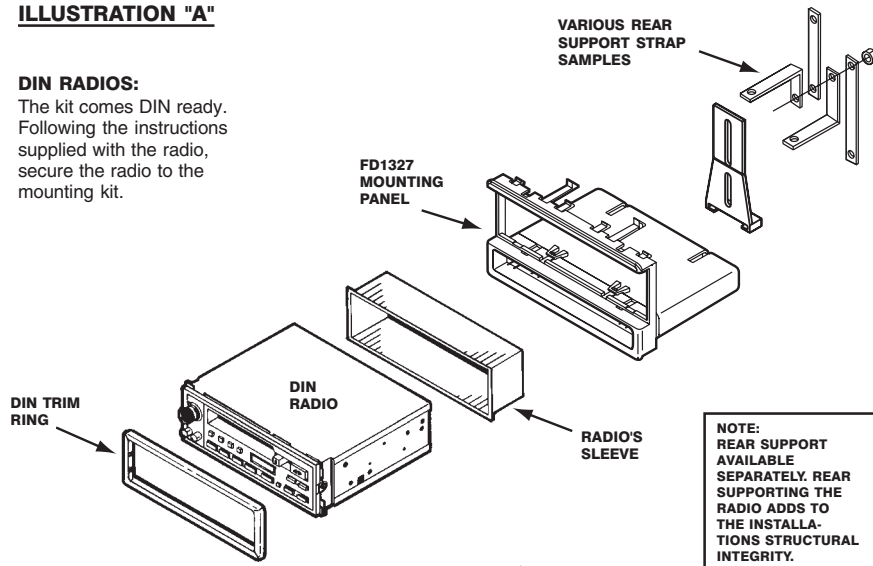

1997-04	Ford Club Wagon	1995-97	Lincoln Continental
1995-04	Ford Crown Victoria	1995-98	Lincoln Mark VIII
1997-04	Ford Econoline	1995-04	Lincoln Town Car
2001-05	Ford Escape	1995-03	Mazda B-Series Pickup
2000-04	Ford Excursion	2001-03	Mercury Cougar
1995-01	Ford Explorer 2/4 DR	1995-03	Mercury Grand Marquis
2001-03	Ford Explorer 2 DR Sport	1996-01	Mercury Mountaineer
2001-03	Ford Explorer Sport Trac		
1999-03	Ford F-Series Super Duty Pickup		
1995-03	Ford Ranger		
1999-03	Ford Windstar		

### RADIO REMOVAL:

1. Insert DIN Removal Tools, spread the tools apart to release factory stereo, slip it out of the dash, unplug and remove radio.

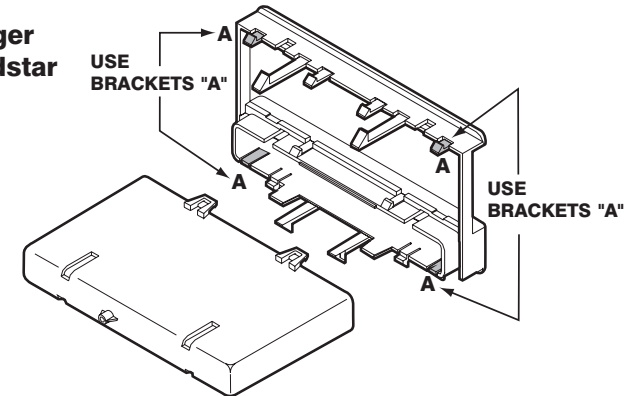

USE THE SHADED BRACKETS. CUT OFF THE REMAINING BRACKETS AND DISCARD.

1999-03	Ford Expedition
1999-03	Ford F-Series Pickup
2004	Ford F-Series Pickup Heritage
2002-03	Lincoln Blackwood
1998-04	Lincoln Navigator

### RADIO REMOVAL:

1. Carefully pry out on radio/dash bezel and unsnap to remove.  
**CAUTION: PASSENGER AIRBAG SWITCH DOES NOT UNPLUG ON PICKUP.**
2. Insert DIN Removal Tools, spread the tools apart to release factory stereo, slip it out of the dash and remove radio.

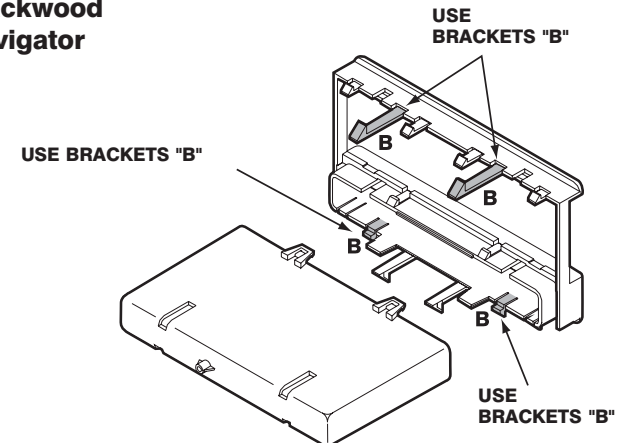

USE THE SHADED BRACKETS. CUT OFF THE REMAINING BRACKETS AND DISCARD.