

IN-DASH INSTALLATION KIT FOR 1982-UP CHEVROLET CAMARO AND PONTIAC FIREBIRD VEHICLES

1993-02 Chevrolet Camaro

Radio Removal:

1. Extract (3) screws from the bottom edge of the dash below the glove box and remove the glove box.
2. Extract (3) screws in the glove box cavity that secure the radio trim bezel to the dash.
3. Extract (2) screws from the center of the underdash panel below the steering column.
4. Extract (2) screws at the bottom edge of the dash below the steering column and remove the underdash panel.
5. Extract (2) screws from where you removed the underdash panel to remove the radio trim bezel.
6. Extract (2) screws securing the radio to the dash on the drivers side and the 10mm bolt securing the radio on the passenger side.
7. Pull the radio from the dash, unplug all connectors and remove the radio.

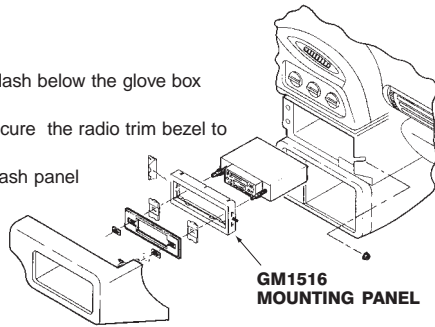

GM1516
MOUNTING PANEL

USE THIS
BRACKET

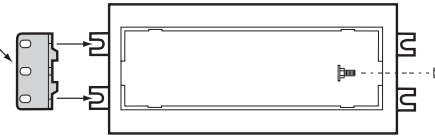

USE THE SHADED MOUNTING TABS AND
THE INDICATED BRACKETS. CUT OFF THE
REMAINING TABS AND DISCARD.

NOTE: Use carriage bolt to attach right side of kit panel directly to the dash's radio mount.

1982-92 Chevrolet Camaro

Radio Removal:

1. Remove (4) splined torque screws from radio trimplate. Use snap-on bit No. SDMT-15 for 1/4" driver. A 3/32" Allen wrench may be used as a substitute.
2. Pull panel up and outward toward right.
3. Remove (4) 7mm hex screws from radio/brackets, pull radio outward.
4. Disconnect power, antenna, speaker and all electrical connections. Remove radio.

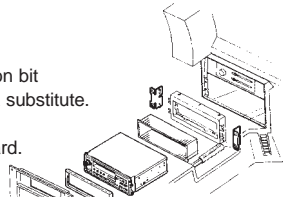

USE THIS
BRACKET

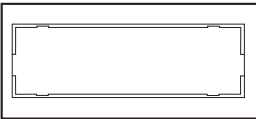

USE THIS
BRACKET

USE THE SHADED MOUNTING TABS AND THE INDICATED
BRACKETS. CUT OFF THE REMAINING TABS AND DISCARD.

1982-92 Pontiac Firebird

Radio Removal: (1982-84 ONLY)

1. Remove (4) splined torque screws from radio trimplate. Use snap-on bit No. SDMT-15 for 1/4" driver. A 3/32" Allen wrench may be used as a substitute.
2. Pull panel up and outward toward right.
3. Remove (4) 7mm hex screws from radio brackets, pull radio outward.
4. Disconnect power, antenna, speaker and all electrical connections. Remove radio.

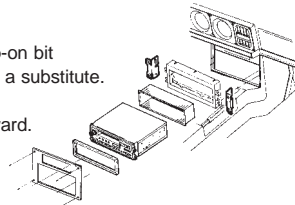

Radio Removal: (1985-92 ONLY)

1. Carefully pull on edges of radio/console trimpanel to release panel clips and remove trimpanel.
2. Remove (4) 7mm hex head sheet metal screws, which secure radio to console, slide radio out of cavity, disconnect wiring, and remove radio.

USE THIS
BRACKET

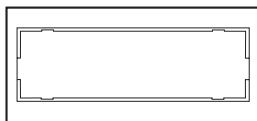

USE THIS
BRACKET

USE THE SHADED MOUNTING TABS AND THE INDICATED
BRACKETS. CUT OFF THE REMAINING TABS AND DISCARD.

ILLUSTRATION A:
1993-UP CHEVROLET CAMARO

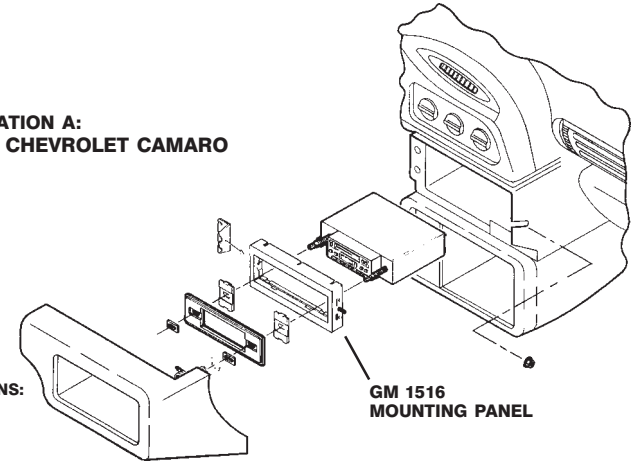

INSTALLATION APPLICATIONS:

- CHEVROLET**
1993-02 Camaro
1982-92 Camaro
- PONTIAC**
1982-84 Firebird
1982-92 Firebird

FACTORY WIRING CODES

<p>PROVIDE EASY CONNECTION OF YOUR CAR STEREO TO FACTORY WIRING HARNESS.</p> <p>GMO1B 1978-87 Select General Motors</p>	
<p>GMO2B 1988-Up Select General Motors</p>	
<p>MDA1B 1988-Up Select General Motors</p>	

LIABILITY DISCLAIMER

This instruction booklet is based on carefully documented data and research of automobile dash disassembly, wire harness/ codes and information pertaining to installation of this kit (#GM1516) in 1982-UP Chevrolet Camaro and Pontiac Firebird Vehicles. Scosche Industries, Inc. can not be held responsible for discrepancies/inconsistencies that may occur due to the automobile manufacturing changes or options, or damage that may occur in the automobiles during the installation of components while using this booklet.

If you have any further questions, call:

TECH HELP 1-800-621-3695, ext. 3

©2006 SCOSCHE INDUSTRIES, INC.

SI 01/06 - GM1516 (3000031)